



Model	CLG2025/30MJ
Drive	Manual
Operator type	Pedestrian
Load capacity	2500 / 3000kg

CLG2025/30MJ PALLET TRUCK

TOP QUALITY PALLET TRUCK

EXCELLENT DESIGNS

Top class range of pallet trucks with excellent designs.

APPLICABLE PLACE

Professional and ideal storage aid for all variety of manual transport tasks over short distances in stores and warehouse as well as factory plants.

RELIABLE,STURDY

Reliable, sturdy, torsion-resistant due to its extremely strong high quality steel profile Germany standard WAGNER painting system ensures best powder coating and painting quality.

STABLE PERFORMANCE

All pivots points are greased ensures excellent maneuverability with effortless steering The chromed bearing bushes and joints ensure quiet running properties and particularly long service life.



INTEGRAL HYDRAULIC PUMP

Excellent galvanized whole casting hydraulic pump, robust and durable, with fine control of lowering speed and overload valve, low routine maintenance.

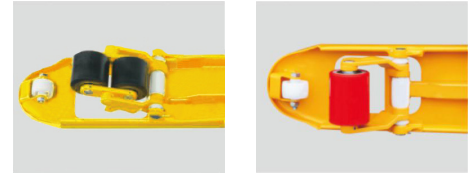

Option of single and tandem fork rollers

Additional entry and exit fork rollers guarantees for maximum stability and safety for transporting goods on slopes.

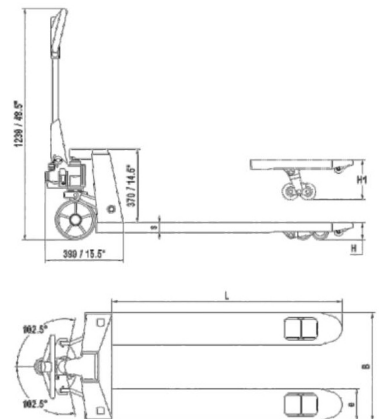

SPECIFICATIONS

HAND PALLET TRUCK		1KG=2.2LB 1INCH=25.4MM			
Item/Type		CLG2025MJ		CLG2030MJ	
Capacity Q	Kg	2500		3000	
Min.fork height h	mm	85	75	85	75
Max.fork height h1	mm	200	190	200	190
Steering wheel	mm	200x50	180X50	200X50	180X50
Load roller Single	mm	80X93	74X93	80X93	74X93
Load roller Tandem	mm	80X70	74X70	80X70	74X70
Size of fork e*s	mm	160X50		160X50	
Width overall forks B	mm	540/685		540/685	
Fork length l	mm	1150/1220		1150/1220	

Conforms to EN 1757-2

ERGONOMICALLY DESIGNED HANDLE

Ergonomically designed handle with comfortable rubber grip allows the optimized safety as well as comfortable. Three position operational handle lever for lifting, transporting and lowering purposes.

Lower Position---to lower load,pull up on the finger tip control.

Neutral Position-to place finger tip control in this position during pulling the truck or load.

Lift Position-to raise load,push down on finger tip control,pump handle to raise the load.

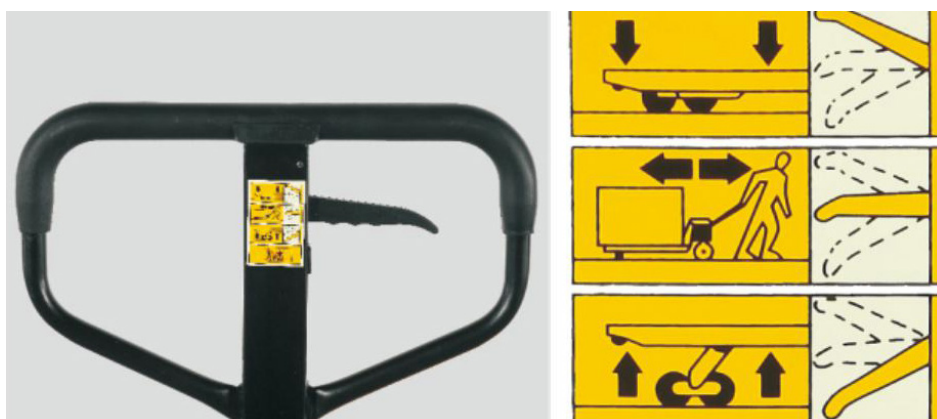

TANDEM FORK ROLLERS

Ideal for heavy loads and uneven floors.



Option of different coating material for both steering wheel and fork rollers.

Polyurethane---Ideal for delicate floors with hard wearing and non-marking property,quiet and durable.

Nylon---low drag efforts,high resistance to chemicals,non-marking,preferred in food,fishing and chemical industries with smooth level floors.

Rubber---Best choice for quiet and durable demands,ideal for smooth and rough floors.



Liuzhou Liugong Forklift Co., Ltd.

No. 1 Yanghe Road, Liuzhou, Guangxi 545007, PR China
T: +86 772 388 6124 E: overseas@liugong.com
HQ: www.liugong.com
MH: www.lgforklift.cn

Like and follow us:



LG-PB-CLG2025/30MJ-022022-ENG

The Liugong series of logos herein, including but not limited to word marks, device marks, letter of alphabet marks and combination marks, as the registered trademarks of Guangxi Liugong Group Co., Ltd. are used by Guangxi Liugong Machinery Co., Ltd. with legal permission, and shall not be used without permission. Specifications and designs are subject to change without notice. Illustrations and pictures may include optional equipment and may not include all standard equipment. Equipment and options varies by regional availability.