

TOUGH WORLD.TOUGH EQUIPMENT.



LG-PB-CDD16-EHT-J-2025-06-EN

The Liugong series of logos herein, including but not limited to word marks, device marks, letter of alphabet marks and combination marks, as the registered trademarks of Guangxi Liugong Group Co., Ltd. are used by Guangxi Liugong Machinery Co., Ltd. with legal permission, and shall not be used without permission. Specifications and designs are subject to change without notice. Illustrations and pictures may include optional equipment and may not include all standard equipment. Equipment and options varies by regional availability.

Liuzhou Liugong Forklift Co., Ltd.
No. 1 Yanghe Avenue, Yanghe Industrial
New Zone, Liuzhou City, Guangxi
Zip Code (P): 545006
Sales Hotline (T): 0772-2040713
Service Hotline (T): 0772-2040720/ 0772-2040721 E-mail
(E): liugonglrs@liugong.com
Website (W): www.lgforklift.cn



Official website



Media Platform

CDD16-EHT-J

ELECTRIC PALLET TRUCK(STANDING ON)



TOUGH WORLD.TOUGH EQUIPMENT.

Electric pallet truck(Standing on)



CDD16-EHT-J

MAIN FEATURES

- **AC Drive Control System**

Delivers powerful performance with precise control and smooth operation.

- **Durable Mast Design**

C-channel + H-beam steel mast combines high strength with excellent bending resistance.

- **Safety-Focused Hydraulics**

Anti-burst valve technology prevents sudden mast drop during hose failure, enhancing operational safety.

- **Operator Protection**

Transparent mast barriers ensure load/operator separation without obstructing visibility.

- **Emergency Handle Functions**

Reverse Override: Instantly reverses motion to avoid crushing risks.

Variable Speed Control: Creep-mode button adjusts travel speed for precision tasks.

- **External Charging Port**

Streamlined external charger simplifies battery replenishment.

- **Easy-Access Maintenance**

Unibody guards with removable screws provide direct access to critical components.

Modular layout centralizes parts for efficient troubleshooting and repairs.



PRODUCT SPECIFICATIONS

| | | | | |
|-------------|---|------------------------------------|-----------------------------|---------------------------|
| General | Product type | Electric pallet truck(Standing on) | | |
| | Model | CDD16-EHT-J | | |
| | Power type | Electric | | |
| | Operation | Standing on | | |
| | Rated traction weight | Q(kg) | 1600 | |
| | Load centre | c(mm) | 600 | |
| | Axle centre to fork face | x(mm) | 675 | |
| Weight | Wheelbase | y(mm) | 1320 | |
| | Service weight with battery | kg | 1305 | |
| | Axle loading, laden driving side/loading side | kg | 1245/1565 | |
| Tire | Axle loading, unladen driving side/loading side | kg | 950/360 | |
| | Wheels type | PU | | |
| | Driving wheel size | Φxw(mm) | Φ250x75 | |
| | Bearing wheel size | Φxw(mm) | Φ80x70 | |
| | Additional wheels (dimensions) | Φxw(mm) | Φ150x58 | |
| | Wheels,number front/rear (x=driven) | 1x,2/4 | | |
| Mast | Track width (driving wheel) | b10(mm) | 828 | |
| | Track width (bearing wheel) | b11 (mm) | 390/515 | |
| | Height of mast, lowered | h1(mm) | 2054 | 2552 |
| | Free lift | h2(mm) | 1561 | 2062 |
| Dimensions | Lift height | h3(mm) | 4500 | 6000 |
| | Handle height (min/max) | h14(mm) | 1063/1440 | |
| | Lowered fork height | h13(mm) | 86 | |
| | Overall length | l1(mm) | 2085 | |
| | Length to fork face | l2(mm) | 925 | |
| | Overall width | b1(mm) | 1060 | |
| | Fork dimensions | s/e/l (mm) | 60/180/1150 | |
| | Distance between fork-arms | b5(mm) | 570/695 | |
| | Min.Ground clearance | m2(mm) | 26 | |
| | Aisle width with pallet 1000 x1200 across forks | Ast (mm) | 2503/2888 | |
| | Aisle width with pallet 800 x1200 along forks | Ast (mm) | 2480/2865 | |
| Performance | Min.Turning radius | Wa(mm) | 1630 | |
| | Travel speed, loaded/unloaded | (km/h) | 5.2/5.5 | |
| | Lifting speed, loaded/unloaded | (mm/s) | 130/220 | |
| | Lowering speed, loaded/unloaded | (mm/s) | 190/140 | |
| Power | Maximum climbing ability, loaded/unloaded | (%) | 6/8 | |
| | Service brake | Electromagnetic | | |
| Battery | Drive motor, 60 minute rating | (kW) | 1.5 | |
| | Lift motor rating at S3 15% | (kW) | 3 | |
| Other | Battery voltage/rated capacity | (V/Ah) | Acid-lead battery 24/240 | Lithium battery 24/200 |
| | Type of drive control | AC | | |
| | Steering type | Electrical | | |
| | Noise level at operator's ear | (dB(A)) | ≤ 70 | |

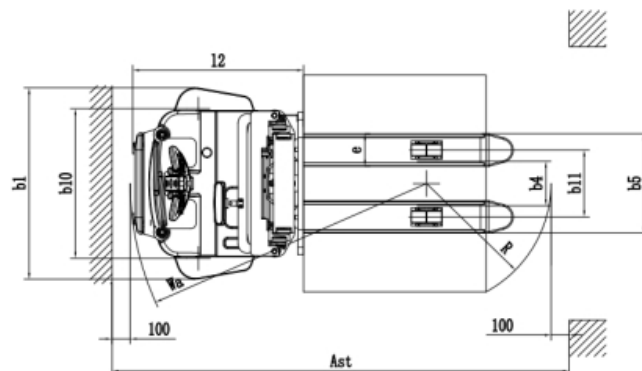
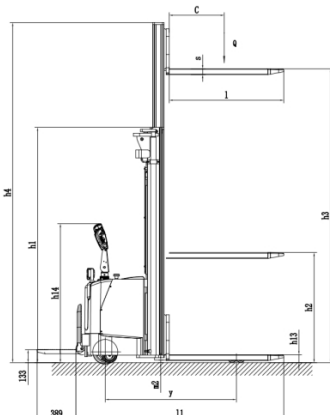

MAST AND CAPACITY INFORMATION

| Mast type | Lift height (h3) mm | Mast height | | | Service weight with mast kg |
|-----------|------------------------|-----------------------------------|----------------------|------------------------------------|--------------------------------|
| | | Height of mast, lowered(h1) mm | Free lift (h2) mm | Height of mast, Extended(h4) mm | |

CDD16-EHT-J

| | | | | | |
|----------------------|------|------|------|------|------|
| 3-stage no full free | 4000 | 1886 | 1396 | 4560 | 1275 |
| | 4500 | 2054 | 1561 | 5060 | 1305 |
| | 4600 | 2086 | 1594 | 5160 | 1310 |
| | 4700 | 2120 | 1327 | 5260 | 1316 |
| | 5000 | 2220 | 1726 | 5560 | 1335 |
| | 5500 | 2386 | 1894 | 6060 | 1370 |
| | 6000 | 2552 | 2062 | 6560 | 1400 |

