

CDD16/20-EMT-J

ELECTRIC PALLET TRUCK(STANDING ON)



TOUGH WORLD.TOUGH EQUIPMENT.

Electric pallet truck(Standing on)



CDD16/20-EMT-J

MAIN FEATURES

- **High-power MOSFETs drive**

High-frequency, high-efficiency, quiet operation with stepless speed control & plugging braking function;

- **Advanced vertical AC drive system**

Delivers more energy to motors and higher braking torque, providing stronger power, higher efficiency, and superior acceleration;

- **Full-series H-beam mast steel (exclusive for forklifts)**

Excellent plasticity and toughness, high bending resistance, and superior structural stability;

- **Standard electronic power steering (EPS)**

Instant response sensitivity with ergonomic and effortless handle control;

- **AC motor advantages**

Minimal components | Zero routine-replacement parts | Near-zero maintenance | Higher efficiency and extreme durability;

- **Standard side-extraction battery configuration**

Enables rapid battery replacement, facilitating continuous operation and boosting productivity by up to 25%;

- **Standard auto-lift cutoff safety**

Automatically cuts power when forks reach maximum height, ensuring smooth stop and preventing overhead collisions.



PRODUCT SPECIFICATIONS

| | | Electric pallet truck(Standing on) | | |
|---|---|------------------------------------|------------------------------------|-----------------|
| | | CDD16-EMT-J | CDD20-EMT-J | |
| General | Product type | | Electric pallet truck(Standing on) | |
| | Model | | CDD16-EMT-J CDD20-EMT-J | |
| | Power type | | Electric Electric | |
| | Operation | | Standing on Standing on | |
| | Rated traction weight | Q (kg) | 1600 | 2000 |
| | Load centre | c (mm) | 600 | 600 |
| | Axle centre to fork face | x (mm) | 639 | 639 |
| | Wheelbase | y (mm) | 1295 | 1295 |
| | Service weight with battery | kg | 940 | 960 |
| Tire | Wheels type | | PU PU | |
| | Driving wheel size | Φxw (mm) | Φ250x75 | Φ250x75 |
| | Bearing wheel size | Φxw (mm) | Φ80x70 | Φ80x70 |
| | Additional wheels (dimensions) | Φxw (mm) | Φ115x55 | Φ115x55 |
| | Wheels,number front/rear (x=driven) | | 1x+2/4 | 1x+2/4 |
| | Track width (driving wheel) | b10 (mm) | 580 | 580 |
| Track width (bearing wheel) | b11 (mm) | 390/515 | 390/515 | |
| Mast | Height of mast, lowered | h1 (mm) | 2049 | 2049 |
| | Free lift | h2 (mm) | 166 | 166 |
| | Lift height | h3 (mm) | 1600 | 1600 |
| | Height of mast,extended | h4 (mm) | 2049 | 2049 |
| Dimensions | Platform height from ground | h7 (mm) | 128 | 128 |
| | Handle height (min/max) | h14 (mm) | 1063/1440 | 1063/1440 |
| | Lowered fork height | h13 (mm) | 86 | 86 |
| | Overall length | l1 (mm) | 2040 | 2040 |
| | Length to fork face | l2 (mm) | 890 | 890 |
| | Overall width | b1 (mm) | 808 | 808 |
| | Fork dimensions | s/e/l (mm) | 60/180/1150 | 60/180/1150 |
| | Width of forks | b5 (mm) | 570/695 | 570/695 |
| | Min.Ground clearance | m2 (mm) | 24 | 24 |
| | Aisle width with pallet 1000 x1200 across forks | Ast (mm) | 2452 | 2452 |
| | Aisle width with pallet 800 x1200 along forks | Ast (mm) | 2432 | 2432 |
| | Min.Turning radius | Wa (mm) | 1570 | 1570 |
| | Performance | Travel speed, loaded/unloaded | (km/h) | 5.2/5.5 |
| Lifting speed, loaded/unloaded | | (mm/s) | 80/210 | 80/210 |
| Lowering speed, loaded/unloaded | | (mm/s) | 152/160 | 152/160 |
| Maximum climbing ability, loaded/unloaded | | (%) | 6/8 | 6/8 |
| Service brake | | | Electromagnetic | Electromagnetic |
| Power | Drive motor, 60 minute rating | (kW) | 1.5 | 1.5 |
| | Lift motor rating at S3 15% | (kW) | 25 | 3 |
| Battery | Battery voltage/rated capacity | (V/Ah) | 24/210 | 24/210 |
| | Battery weight (+5%) | (kg) | 210 | 210 |
| Other | Type of drive control | | AC | AC |
| | Noise level at operator' s ear | (dB(A)) | 70 | 70 |

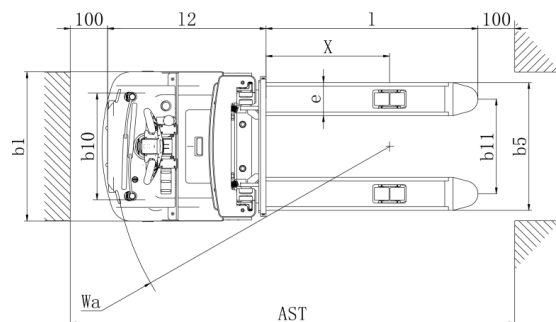
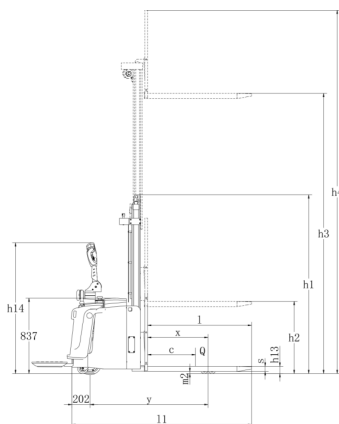

Electric pallet truck(Standing on)

| Mast table | | | | | | | | | | |
|--------------|-----------------|------------------------------|---------------|-------------------------------|--------------------------|-----------------|------------------------------|---------------|-------------------------------|--------------------------|
| CDD16-EMT-J | | | | | | CDD20-EMT-J | | | | |
| Mast type | Lift height(h3) | Mast height | | | Service weight with mast | Lift height(h3) | Mast height | | | Service weight with mast |
| | | Height of mast, lowered (h1) | Free lift(h2) | Height of mast, Extended (h4) | | | Height of mast, lowered (h1) | Free lift(h2) | Height of mast, Extended (h4) | |
| | mm | mm | mm | mm | kg | mm | mm | mm | mm | kg |
| single stage | 1600 | 2049 | 166 | 2049 | 940 | 1600 | 2049 | 166 | 2049 | 960 |
| 2-stage | 2000 | 1499 | 166 | 2408 | 980 | 2000 | 1499 | 166 | 2408 | 995 |
| | 2500 | 1749 | 166 | 2908 | 1025 | 2500 | 1749 | 166 | 2908 | 1035 |
| | 3000 | 1999 | 166 | 3408 | 1065 | 3000 | 1999 | 166 | 3408 | 1090 |
| | 3300 | 2149 | 166 | 3708 | 1085 | 3300 | 2149 | 166 | 3708 | 1115 |
| | 3500 | 2249 | 166 | 3908 | 1095 | 3500 | 2249 | 166 | 3908 | 1130 |
| | 3600 | 2299 | 166 | 4008 | 1105 | 3600 | 2299 | 166 | 4008 | 1135 |
| | 4000 | 2499 | 166 | 4408 | 1130 | 4000 | 2499 | 166 | 4409 | 1170 |

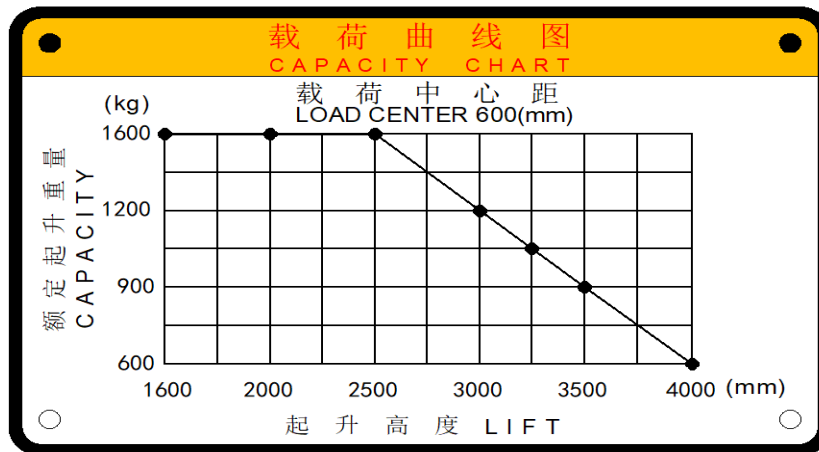

Load chart CDD16-EMT-J

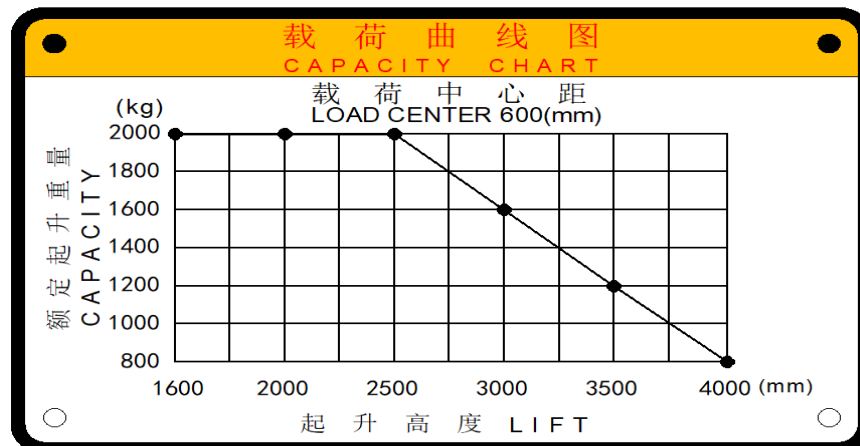

Load chart CDD20-EMT-J

TOUGH WORLD.TOUGH EQUIPMENT.



LG-PB-CDD16/20-EMT-J-2025-06-EN

The Liugong series of logos herein, including but not limited to word marks, device marks, letter of alphabet marks and combination marks, as the registered trademarks of Guangxi Liugong Group Co., Ltd. are used by Guangxi Liugong Machinery Co., Ltd. with legal permission, and shall not be used without permission. Specifications and designs are subject to change without notice. Illustrations and pictures may include optional equipment and may not include all standard equipment. Equipment and options varies by regional availability.

Liuzhou Liugong Forklift Co., Ltd.
No. 1 Yanghe Avenue, Yanghe Industrial
New Zone, Liuzhou City, Guangxi
Zip Code (P): 545006
Sales Hotline (T): 0772-2040713
Service Hotline (T): 0772-2040720/ 0772-2040721 E-mail
(E): liugonglrs@liugong.com
Website (W): www.lgforklift.cn



Official website



Media Platform