

SPECIFICATION

General	Model	1			CPCD40	
	Power Type	2			Diesel	
	Load Capacity	3		kg	4000	
Weights	Load Center Distance	4	@ rated load center	mm	500	
	Service Weight	5	unloaded	kg	5480	
	Axle Load	6	loaded,front/rear	kg	8335/1145	
Tires		7	unloaded,front/ rear	kg	2225/3255	
	Tire Type	8			Pneumatic	
	Wheels	9	front / rear		2/2	
	Wheelbase	10		mm	1880	
	Tire Size	11	front		250-15-18PR	
Mast		12	rear		7.00-12-12PR	
	Tread Width	13	front/rear	mm	1180/1112	
	Max. Fork Height	14	with std 2-stage mast	mm	3000	
	Free Lift	15	with std 2-stage mast	mm	130	
	Height, Upright Lowered	16	with std 2-stage mast	mm	2175	
	Height, Upright Extended	17	with std 2-stage mast	mm	4180	
	Mast Tilt, Fwd/Back	18	with std 2-stage mast	°	6 /12	
	Fork Carriage	19	width	mm	1380	
	Fork Spread	20	minimum/maximum	mm	330/1380	
	Fork Dimension	21	T x W x L	mm	50x122x1070	
Chassis	Length to Fork Face	22	with std 2-stage mast	mm	2950	
	Overall Width	23		mm	1420	
	Overhead Guard Height	24		mm	2175	
	Turning Radius	25	minimum outside	mm	2680	
	Fork Overhang	26	with std 2-stage mast	mm	510	
	Min.Right Angle Stacking Aisle Width	27	add load length and clearance	mm	4460	
	Ground Clearance	28	loaded below mast	mm	145	
Performance		29	center of wheelbase	mm	175	
	Travel Speed	30	loaded/unloaded	km/h	18.5/19	
	Lift Speed	31	loaded/unloaded	mm/s	390/410	
	Lowering Speed	32	loaded/unloaded	mm/s	400/410	
	Max. Drawbar Pull	33	loaded	N	19613	
Systems	Max. Gradeability	34	loaded/unloaded	%	20 / 18	
	Brakes	35	service		Foot/Hyd	
36		parking			Hand /Mech	
Internal combustion	Engine	37	manufacturer		Isuzu	
		38	model		4JG2-B-A-05-C2	
		39	emission compliance		EU Stage II	
		40	cylinders		4	
		41	displacement	L		3.059
		42	rated power	kW/rpm		44.9/2450
		43	max. torque	N.m/rpm		184.7/1700

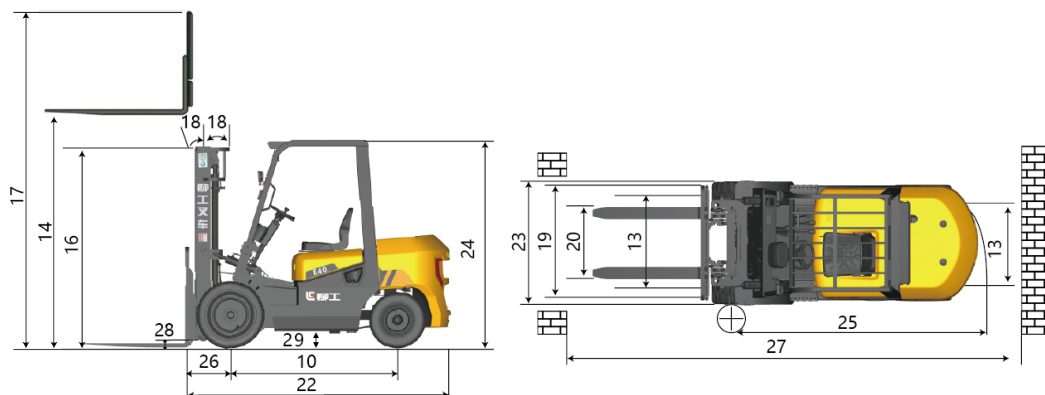

LIUGONG

E SERIES



Engine	Isuzu
Fuel	Diesel
Rated load	4000 kg
Rated Power	44.9 kW

CPCD40

***E SERIES INTERNAL COMBUSTION
COUNTERBALANCED FORKLIFT***

TOUGH WORLD. TOUGH EQUIPMENT.