

PRODUCT SPECIFICATIONS

General	Model	1			CPCD25	
	Power Type	2			Diesel	
	Load Capacity	3		kg	2500	
Weights	Load Center Distance	4	@ rated load center	mm	500	
	Service Weight	5	unloaded	kg	3570	
	Axle Load	6	loaded, front/rear	kg	5300/760	
Tires		7	unloaded, front/ rear	kg	1360/2210	
	Tire Type	8			Pneumatic	
	Wheels	9	front / rear		2 / 2	
	Wheelbase	10		mm	1650	
	Tire Size	11	front		7.00-12-12PR	
Mast		12	rear		6.00-9-10PR	
	Tread Width	13	front/rear	mm	960/970	
	Max. Fork Height	14	with std 2-stage mast	mm	3000	
	Free Lift	15	with std 2-stage mast	mm	140	
	Height, Upright Lowered	16	with std 2-stage mast	mm	2070	
	Height, Upright Extended	17	with std 2-stage mast	mm	4025	
	Mast Tilt, Fwd/Back	18	with std 2-stage mast	°	6 / 12	
	Fork Carriage	19	width	mm	1040	
	Fork Spread	20	minimum/maximum	mm	272/1072	
	Fork Dimension	21	T x W x L	mm	40 x 122 x 1070	
Chassis	Length to Fork Face	22	with std 2-stage mast	mm	2630	
	Overall Width	23		mm	1150	
	Overhead Guard Height	24		mm	2100	
	Turning Radius	25	minimum outside	mm	2230	
	Fork Overhang	26	with std 2-stage mast	mm	476	
	Min.Right Angle Stacking Aisle Width	27	add load length and clearance	mm	4015	
	Ground Clearance		28	loaded below mast	mm	110
			29	center of wheelbase	mm	120
Performance	Travel Speed	30	loaded/unloaded	km/h	19/ 20	
	Lift Speed	31	loaded/unloaded	mm/s	530/550	
	Lowering Speed	32	loaded/unloaded	mm/s	420/510	
	Max. Drawbar Pull	33	loaded	N	16475	
	Max. Gradeability	34	loaded/unloaded	%	18/ 20	
Systems	Brakes	35	service		Foot/Hyd	
		36	parking		Hand /Mech	
Internal combustion	Engine	37	manufacturer		Isuzu	
		38	model		C240-NBKEG-01-C3	
		39	emission compliance		EU III	
		40	cylinders		4	
		41	displacement	L		2.369
		42	rated power	kW/rpm		35.4/2500
		43	max. torque	N.m/rpm		137.7/1800

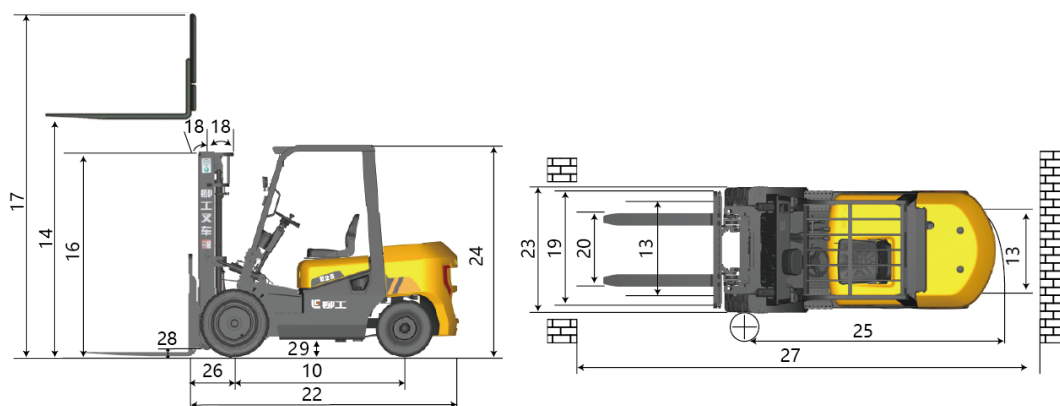

LIUGONG

E SERIES



Engine	Isuzu
Fuel	Diesel
Rated load	2500kg
Rated Power	35.4 kW

CPCD25

***E SERIES INTERNAL COMBUSTION
COUNTERBALANCED FORKLIFT***

TOUGH WORLD. TOUGH EQUIPMENT.